



R-A12
Weighing
Indicator
User Manual

V1.01

Shanghai Yaohua Weighing System Co., Ltd

Table of Contents

Chapter I. Technical Data.....	- 2 -
Chapter II Installation Connection.....	- 3 -
I. Instrumentation Diagram.....	- 3 -
II. Sensor Connection	- 3 -
III. Serial Communication Interface and Large Screen.....	- 4 -
Chapter III Operation Instruction.....	- 5 -
I. Startup	- 5 -
II. Key Operation	- 5 -
III. Weighing Operation	- 6 -
Chapter IV Calibration Description	- 8 -
Note: unplug the short-circuit ring after calibration.	- 9 -
Chapter V Error Indication	- 9 -
Chapter VI Battery.....	- 10 -

Dear users:

Please read the instruction manual carefully before using this indicator.

This indicator shall not be used for public trading!!!

Chapter I.

1. Model	R - A 1 2 Technical Data	
2. Analog	Input signal range	-19mV~19mV
	Conversion speed	More than 10 times/s
	Nonlinearity	0.0015%
	Gain drift	0.03%
	Bridge voltage	DC 5V
	Sensor connection	1-4 350Ω sensors
3. Indication	Indication range	-99999~999999 (decimal point is not considered)
	Scale interval	1/2/5/10/20/50 optional
4. Serial communication interface	Signal	RS232 signal
	Transmission distance	<20m
5. Operating environment	Power supply	AC220V; 50, 60Hz (-2%~+2%)
	Operating temperature	-10 ℃ ~40 ℃
	Storage and transport temperature	-25 ℃ ~55 ℃
	Relative humidity	≤85%RH
	Fuse	500mA
6. Weight	Approx. 2 kg	

Chapter II Installation Connection

I. indicator Diagram

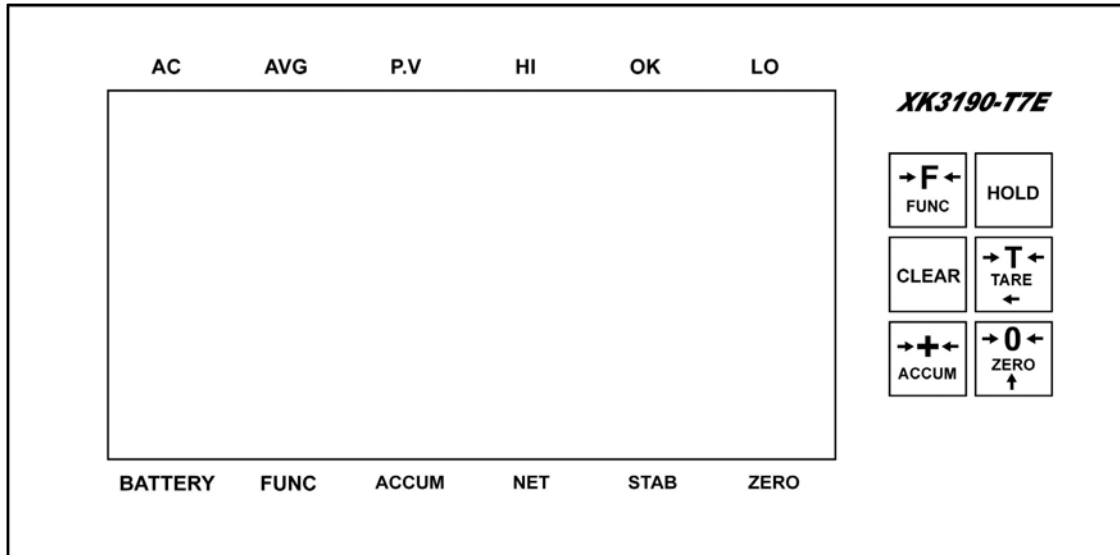

(Figure 2-1) Front cover

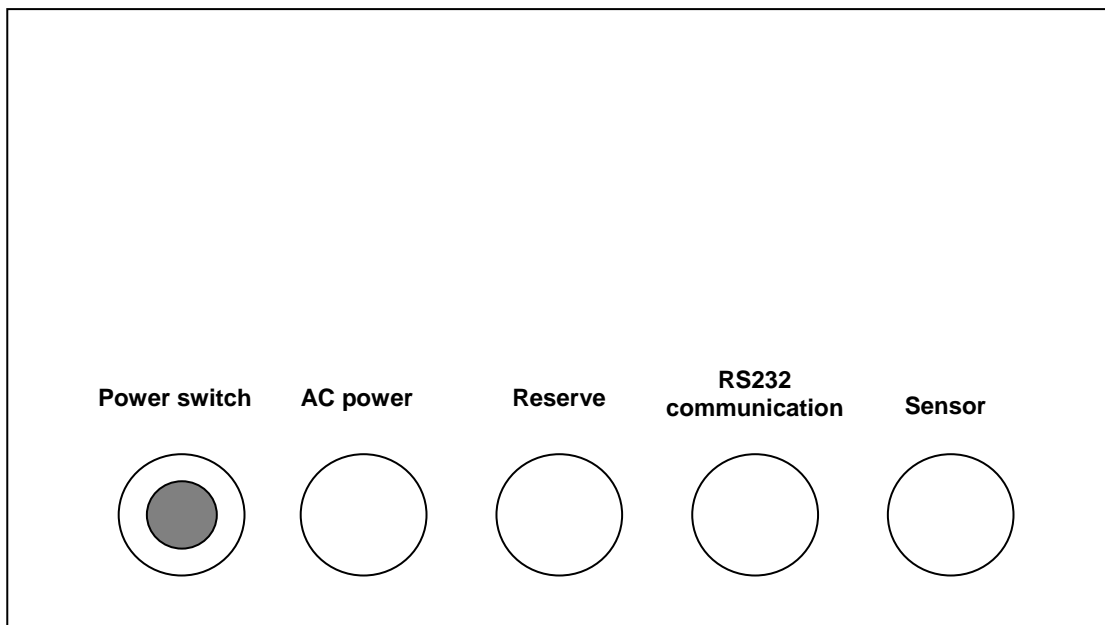

(Figure 2-2) Back cover

II. Sensor Connection

1. The sensor is connected through 9-pin plug socket (hole). Figure 2-3 shows the meaning of each lead pin.
2. Please use 6-core shielded cable to ensure perfect metering performance of instrument.

R-A12

If there is only 4-core shielded cable on site, pins 1 & 2 and 6 & 7 can be shorted at the 9-pin sensor connector.

▲! The connections of sensor and instrument must be reliable, and the shielded cable of sensor must be reliably grounded. Connections lines shall not be plugged and pulled when the instrument is in a Power-up State in order to prevent static electricity damaging the instrument or sensor.

▲! Since both sensor and instrument is static-sensitive device, anti-static measures must be practically taken in the use, and welding or other strong-electric operations on weighing platform are strictly prohibited. In the thunderstorm season, reliable lightning protection measures must be taken to prevent lightning damaging the sensor and instrument and to ensure the operator safety and the safe operation of weighing equipment and related equipment.

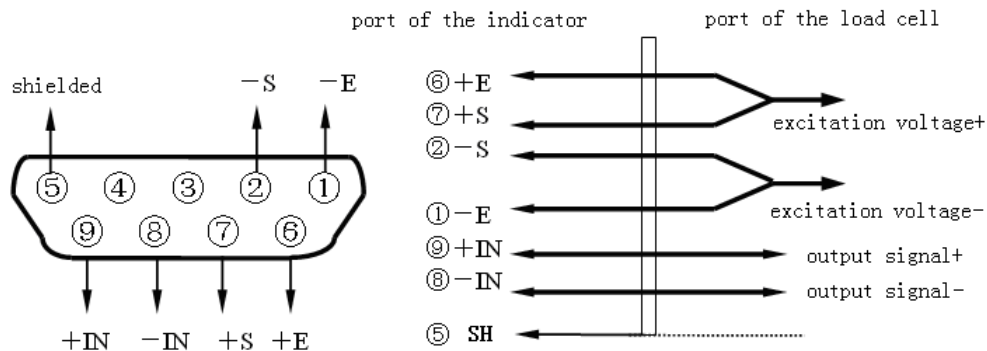

(Figure 2-3) Sensor connection

Please short E- and S-, E+ and S+ if 4-core shielded cable is used, or the indicator will not work properly.

III. Serial Communication Interface and Large Screen

Serial communication interface

1. The data communication between R-A12 and upper computer is realized through serial communication interface in a continuous way.
2. Connection mode
R-A12 communication interface uses 9-pin socket (pin). Lead pin is defined as follows: pin 2 is for TXD (serial communication data line) and pin 5 is for ground wire; shielded cable is recommended to be used as connections

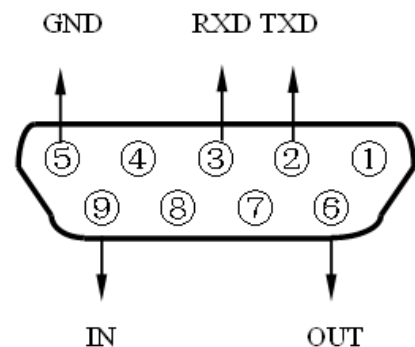

(Figure 2-4) Communication and large screen connection

.line. See Figure 2-4 for details

3. Interface parameter

- ① Signal: RS232C
- ② Baud rate: 600/1200/2400/4800/9600. See the chapter of calibration instruction for baud rate setting methods.
- ③ Data format: = <Weight data (including decimal point)>, all data are in ASCII format.

Note: = data format header, ASCII code.

<Weight data (including decimal point)>: 6 digits (including decimal point) of weight data with symbol, ASCII code.

The lower digits are in front, and the higher digits and symbol digits are in the rear. Negative symbol bit is "-", and positive symbol is "0".

For example, if the weight shown in the indicator is -500.00kg, the serial output data will be "= 00.005-".

If the weight shown in the indicator is 500.00kg, the serial output data will be "= 00.0050".

Large screen

See Figure 2-4 for wiring details. Large screen signal is current loop signal of 20mA constant current and is output in a serial way through binary code, with a baud rate of 600. Each frame has 11 data bits, including one start bit (0), eight data bits (LSB in front), one flag bit, and one stop bit (1).

Chapter III Operation Instruction

I. Startup

The instrument gets into self-check process after the power supply is connected. If the weight on platform is within the startup zero setting range, automatic zero setting will working, than the weighing state is enabled. If the weight on platform exceeds the zero setting range, the indicator will give tips and indicate the said weight.

II. Key Operation

In the calibration and parameter setting state, some keys will perform the following functions:

1. ZERO key performs the "plus 1" function. After the ZERO key is pressed, the figure displayed in the last bit will be "plus 1", automatic zero setting will be made after it is added to 9.
2. TARE key performs the "shift" function. After the TARE key is pressed, the figure shown in the last bit will move to the left for one bit, and the last bit will be supplemented with 0. If the 6-bit indication or effective bit is exceeded after the movement of some one figure to the left, the figure will be discarded.
3. HOLD key performs "input" function. Press the HOLD key to put the set data into indicator.
4. CLEAR key performs "exit" function. Press the CLEAR key to exit calibration or state setting.

III. Weighing Operation

1. ZERO:

Press ZERO key to enable the data within zero setting range of instrument to return to zero. Zero setting can be performed only after the STABLE indication lights.

2. TARE:

When the displayed weight in weighing state is positive and the STABLE light will on, press the TARE key to deduct the indicated weight (as the tare). In this case, the instrument will show a net weight of "0" and the NET WEIGHT lights will on. Press the TARE key again when gross weight is 0, the instrument will clear the tare value.

3. Magnification:

Press the FUNCTION key when tare value is 0 in weighing state, the weighing accuracy will be 10 times larger, and press the FUNCTION key again to return normal (magnification of net weight cannot be shown, and the data cannot be enlarged beyond the range of display).

4. HOLD, average value:

Press HOLD key in weighing state, the PEAK VALUE light will on which indicates peak value. If the current weight is less than 5% of full capacity, it will return normal; press the HOLD key again, the AVERAGE VALUE light will on. In this case, when it becomes stable relatively (the indicator will make automatic determination on whether it is stable), the indicator will calculate the average value and show it after flashing. The average value will be cancelled when the current weight returns to "0", and the next average value can then be measured; press the HOLD key again, the instrument will return to normal weighing mode. In this case, the HOLD key can be pressed to convert the mode.

5. Manual accumulation of measured value:

Press the "ACCUMULATION" key when the measured value is larger or equal to 20 divisions and the data is stable in the normal weighing state, the indicator will perform "manual accumulation" function. In this case, the indicator will indicate the total accumulation data (in two steps): [total =] (indicating that the content shown below is the amount of accumulation data) will show the accumulation data [*****] in about 1 second. The times of accumulation will be then indicated (in two steps): [n =] (indicating that the times is shown below) will show the times of accumulation [***] in about 1 second. The ACCUMULATION indicating light is then on.

Note: the maximum times of accumulation is 9999 (when accumulation result is ensured to be ≤999999); The accumulation results will be held before they are cleared and the data will not be lost after power-off. When the ACCUMULATION key is pressed, if the net weight is less than 20 divisions, only the accumulation value will be indicated, and the accumulation of weight and times will not be made.

6. Automatic accumulation of measured value:

Press the FUNCTION and ACCUMULATION keys at the same time in normal weighing state and not the peak value holding and average value state, the indicator will enter the automatic accumulation

R-A12

state. In this case, the ACCUMULATION light is on. In the automatic accumulation state, the indicator will perform an automatic accumulation and indicate the times of accumulation and the results whenever the measured data is larger than or equal to 20 divisions and after about 1-2 seconds after the data is stable. Re-press the FUNCTION and ACCUMULATION keys at the same time or press HOLD key to exit the automatic accumulation. **Note: automatic accumulation state will be saved when the power is off; however, the accumulation data will be saved.**

7. Clear the accumulation result:

Press the CLEAR key in weighing state, the indicator will clear the times of accumulation and the overall accumulation data.

8. Switching between kg and lb:

Press the FUNCTION and HOLD keys at the same time in normal weighing state, the indicator will perform switching between units; when the measurement unit is lb, the last digit behind decimal point of the shown data is on. Note: if one unit has been used for an accumulation operation and the accumulation results are not cleared (in this case, the accumulation light is on or flashes at low frequency), the indicator will forbid switching between units which can be conducted only after the results are cleared. The switching between units is forbidden when the tare is not "0".

9. Preset tare and upper & lower limits alarm:

Press the FUNCTION and TARE keys at the same time in normal weighing state, the indicator will perform the "preset tare" function in the following steps:

Step	Operation	Display	Description
1		[*****]	Weighing indication status
2	Press FUNCTION + TARE	[P00000]	Guide the user to enter preset tare value.
3	Input the preset tare value, e.g. "6000"	[6000]	Press ZERO key for six times to set the lowest digit to "6", and press the TARE key for three times to change the value to "6000". Press the HOLD key to make confirmation and move to Step 4.
4	Upper limit alarm value, e.g. "3000"	[H 00000]	Press ZERO key for six times to set the lowest digit to, and press the TARE key for three times to change the value to "3000". Press the HOLD key to make confirmation and move to Step 5.
5	Lower limit alarm value, e.g. "0"	[L 00000]	Press the ZERO key to set the lowest digit to "0", and press the TARE key to change the value to "00000". Press the HOLD key to make confirmation and move to Step 6.
6		[*****]	Go back to weighing mode., displaying net weight after tare.

[Note]: cancel the upper and lower limit alarm operation when both the upper and the lower limit is 0; press the CLEAR key to cancel the setting at any time while setting, the current setting data will not be saved; however, the data before the current step will be saved.

10. Auto-sleep function

If the indicator is in a continuously steady state and there is no any key and measurement operations (setting for 30 or 60 seconds as optional), it will automatically enter into auto-sleep state. In this

condition, only last decimal light is on. If there is any key operation in mode 1 or mode 2, the indicator will automatically exit the sleep state and get into normal work state; only by pressing the keys in mode 3 or mode 4 can the instrument exit the sleep state. See the table in Chapter IV for specific settings.

Chapter IV Calibration Description

- I. Properly connect the signal source and power supply to preheat the indicator for 15-30 minutes when there is no load on weighing platform. connect the calibration short-circuit ring in normal weighing state while pressing the FUNCTION and CLEAR key at the same time, the indicator will get into calibration state.

The position of calibration switch on circuit board is JP7.

[Note]: Please refer to the second section of the third chapter about the key operation before next operation.

II. Calibration procedure

Step	Operation	Display	Description
1		[*****]	Weighing mode
2	Press FUNCTION + CLEAR keys	[P ***]	The password of calibration. The password is 111.
3	Input the password and press the HOLD key to confirm	[d *]	Division setting: display the original division parameter and guide the user to enter a new division parameter.
4	Input a new division parameter, e.g. "1": press the ZERO key once to set the indicated data to "1" and press the HOLD key to confirm	[d 1]	The range of this parameter is 1, 2, 5, 10, 20 and 50; if the division value parameter to be entered is the same with the currently displayed value, you can press the HOLD key to move to Step 4.
5		[dP *]	Decimal number setting: display the original number of decimal and guide the user to enter a new number of decimal
6	Input a new number of decimal, e.g. "3": press the ZERO key for three times to set the indicated data as "3" and press the HOLD key to confirm.	[dP 3]	The parameter ranges from 0 to 3; "0" means there is no decimal, and 1-3 means 1-3 decimal; if the number of decimal to be entered is the same with that of the currently displayed decimal digit, you can press HOLD key to move directly to Step 6.
7		[F*****] (F is not displayed when the measuring range occupies 6 digits)	Full-capacity setting: display the original full capacity and guide the user to input a new full capacity. (If the value 3190 is input, you can press the HOLD key to return to weighing mode. Restart the indicator and the factory setting will be recovered)
8	Input a new full capacity, e.g. "6000": press the ZERO key for six times to set the lowest (last) digit as "6", and press the TARE key for three times to change the data to "6000", and then press the HOLD key to confirm.	[6000]	If no need of zero and full value calibration currently, you can press the HOLD key to move to Step 13. If re-calibration is required, the full capacity must be input again before Step 8 and 9.
9		[noloAd]	Zero calibration: in this case, the indicator will check the zero position automatically. If zero position has never been calibrated the zero inner code will be displayed, or the Step 9 will be

R-A12

			moved to rapidly
10		[LoAd]	Full-capacity calibration: indicator zero position has been confirmed and the user is guided to load the weight for full-capacity calibration. In this case, a weight which is more than 1/2 of full capacity can be loaded.
11	After the weight is loaded, wait a few seconds to press the HOLD key	[*****]	The indicator displays the current inner code for the weight loaded to scale. If the loaded weight is too small, you shall go back to Step 9 for re-loading of weight.
12		[*****]	After the data is stable, the indicator will calculate and display the weight according to original calibration rate.
13	input the value of current actual weight on the scale, e.g. "3000": press the ZERO key for three times to set the lowest (last) digit to "3", and press the TARE key to change the data to "3000", and then press the HOLD key to confirm.	[3000]	If the weight to be input is same as the actual weight on weighing scale, you can directly press the HOLD key to move to Step 13.
14	Baud rate	[bt *]	Baud rate setting: display the original baud rate of indicator, and guide the user to input new baud rate. 0:600 1:1200 2:2400 3:4800 4:9600 Press the HOLD key to move to Step 14.
15	Operation in ZERO zone	[n ABCD]	A - Zero tracking range (0-5) means 0, 0.5e, 1e, 1.5e, 2e and 2.5e. B - Manual zero setting range (0-5) 0, 2, 4, 10, 20, 100 (100%) C - Startup zero setting range (0-5) 0, 2, 4, 10, 20, 100 (100%) D - Stability scope (1-5). the larger value the stronger stability of indicator. The way to change input value is the same as above. Press the HOLD key to move to Step 15.
16	Display mode	[LEd AB]	A - Display the brightness. Larger values indicate higher brightness (0-5) B - Power saving mode. 0: saving mode off; 1: about 30 seconds; 2: about 60 seconds 3: 30 seconds 4: 60 seconds Modes 3 and 4 are of strong power saving mode, you can exit the power saving mode only by pressing the key The way to change input value is the same as above. C - Power status light refreshes time. 0: 5 seconds; 1: 30 seconds. Press the HOLD key to move to Step 16.
16		[*****]	Calibration is complete. Return to weighing mode.

Note: unplug the short-circuit ring after calibration.

Chapter V Error Indication

- [Err 1] Inner code loaded is too small or the capacity of load cell is too large
- [Err 2] Out of manual zero setting range
- [Err 5] Inner code loaded is too small or the capacity of load cell is too large
- [Err 7] The calibration short-circuit ring did not connected

R-A12

[-----]	Out of display range
[A oL]	Out of the maximum times of accumulation or weigh of accumulation
[HHHHHH]	Zero position is too high or there is heavy object on weighing platform when the indicator is on

Chapter VI Battery

I. The battery will be charged after power cord is connected to AC 220V power supply. So please remove the battery if it is not used frequently.

In order to avoid internal over-heat and battery over-charging, the current will be limited. If you feel that charging is too slow, please buy a special charger for external charging. Please note that the wire ends connected to battery shall not be connected inversely (red +, black -), or the indicator may burn out.

Be sure to fully charge the battery before using the built-in battery for the first time!

II. When the indicator is battery-powered, it will automatically switch to AC supply mode once the AC power supply is connected; in this case, the AC indicating lamp will light on. There are battery level indications at the lower left corner of indicator screen. The indicator will automatically cut off the DC power supply after the last indicating lamp goes out. Please charge the battery immediately in this situation. The current battery voltage can be displayed when the indicator is started. Please pay attention to this data from time to time.

III. Please charge the battery for about 10-16 hours before its first use so as to avoid a too low voltage caused by self-discharging of battery which may be mistakenly taken as failure.

IV. The battery shall be charged for about 10-16 hours at a time during the normal operation. If the indicator is not to be used for long, the battery shall be charged for 10-16 hours every two months in order to extend its service life.

V. The built-in battery of indicator is a consumable part that is not within the range of "three guarantees".